

SECTION A

NOTES:

1. ENCLOSURE MATERIAL SHALL MATCH BUILDING MATERIAL.
2. NO CHAIN LINK FENCING W/ SLATS SHALL BE PERMITTED.

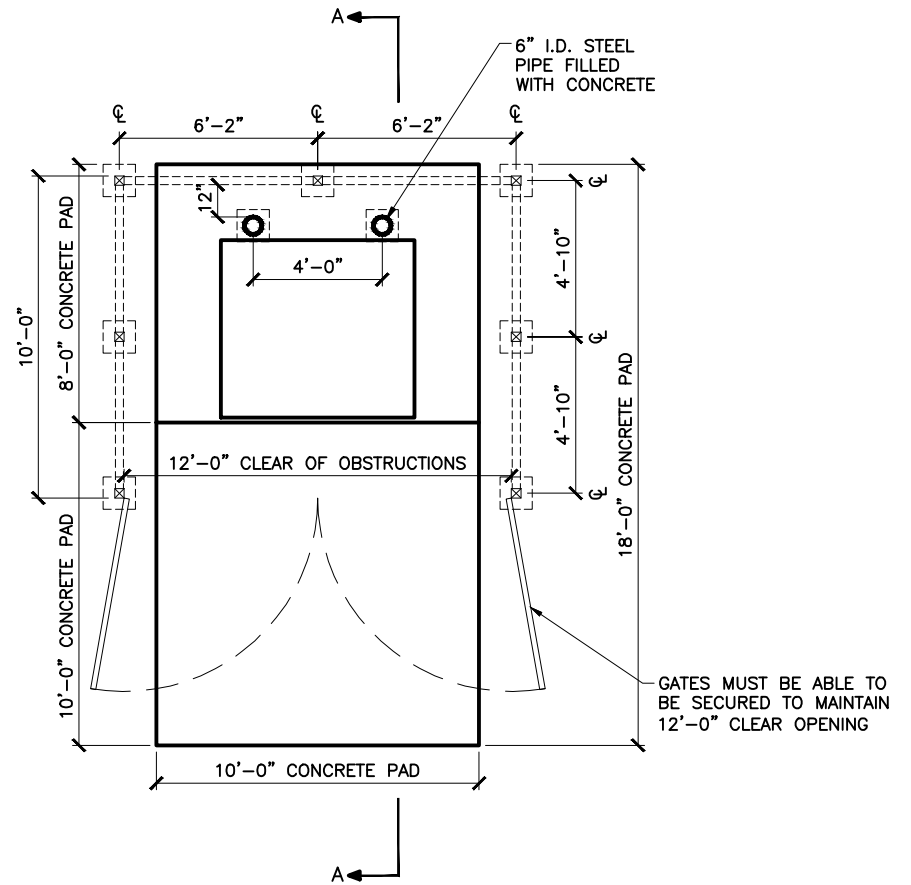

PLAN

GATES MUST BE ABLE TO BE SECURED TO MAINTAIN 12'-0" CLEAR OPENING

NOT TO SCALE



SINGLE DUMPSTER PAD

SEPTEMBER 2022

411