

**NOTES:**

1. THIS MEASURE IS USED WHERE A DISTURBED DITCH FLOWS INTO A PROPOSED FES.
2. WIRE SCREEN SHALL BE 3/4" AND THE BOTTOM SHALL BE TRENCHED A MINIMUM OF 6" INTO THE GROUND AND HELD IN PLACE WITH #57 STONE.
3. ONCE DITCH IS STABILIZED, REMOVE WIRE SCREEN AND FILL BASIN WITH SUITABLE MATERIAL. INSTALL EXCELSIOR MATTING OVER BASIN TO STABILIZE FILL.

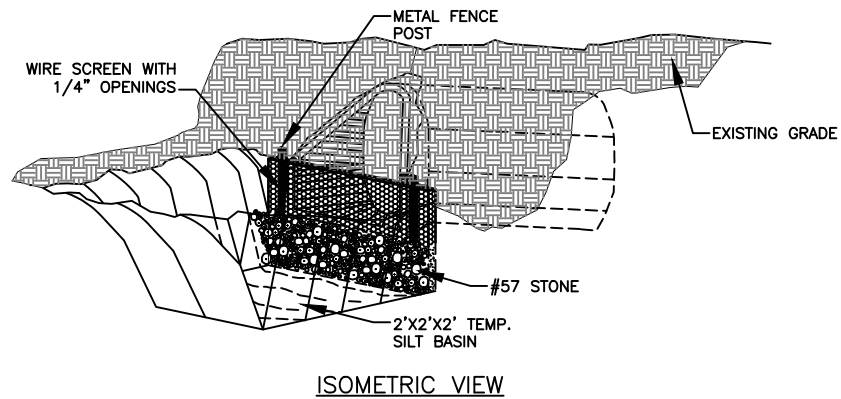

NOT TO SCALE

**FLARED END SECTION**  
**INLET PROTECTION**